

# IQE MIRATECH CATALYST HOUSINGS



Low Cost, High Value Catalyst Reduction



**Carbon Steel Housings**  
Standard with High  
Temperature Black Paint

Also available in  
304 Stainless Steel

**Flat-Top Bonnet™**  
Element Design to  
Eliminate Blow-By



## HIGH PERFORMANCE, LONG LIFE, HIGH VALUE

Apex Element is Virtually Indestructible

- ❑ Designed to cut a wide range of regulated emissions down to compliance levels.
- ❑ Low cost of ownership with quick & easy maintenance
- ❑ Reduces NOx, CO, VOC, HAP and PM
- ❑ Designed for Natural Gas, LPG, Diesel or Dual-Fuel
- ❑ Lean-Burn or Rich-Burn Engines 150 kW – 6MW
- ❑ Catalyst slots for one or two elements give users flexibility to improve emissions reductions
- ❑ Perimeter gasket provides durable and reliable seal
- ❑ Sensor ports for temperature, pressure and O<sub>2</sub>

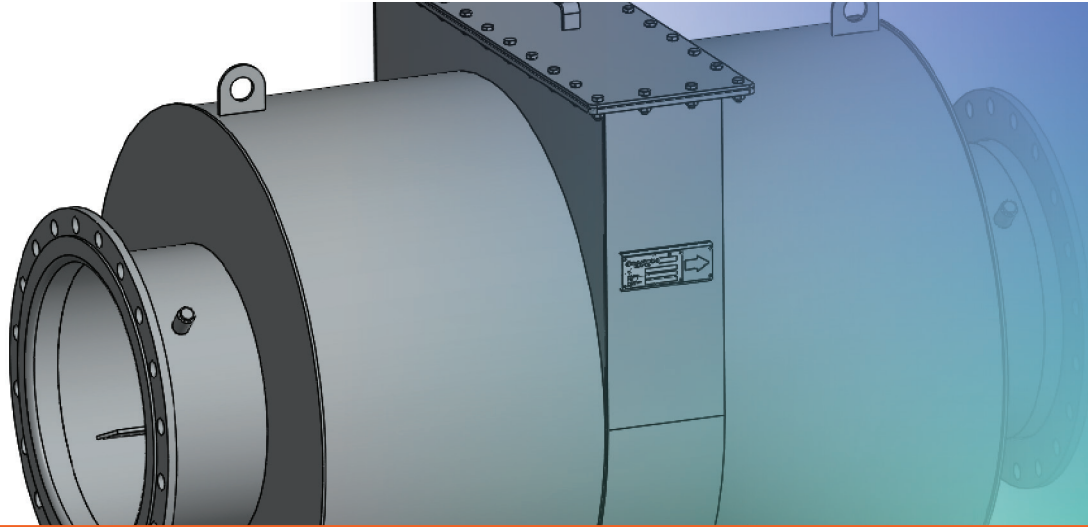

## IQE | INDUSTRIAL CATALYST SYSTEM

### BETTER DESIGNED BETTER BUILT

The tough, durable IQE housing is made of A-36 carbon-steel or stainless—your choice—with bolt holes straddling the centerline. Inside the easy-access catalyst lid, you'll find one of a long line of MIRATECH innovations: the patented Flat-Top Bonnet™ design catalyst element with improved gasket material for a better seal.

Together, these eliminate blow-by, sagging and telescoping, while evening out pressure across the catalyst surface and maximizing catalyst efficiency. The result? You get more out of your catalyst investment.

Each MIRATECH catalyst element features a multi-layer corrugated metal and flat foil honeycomb structure to prevent nesting. Also, the chemisorption catalyst impregnation process produces a long-lasting washcoat that resists catalyst poisoning. The metal monolith construction along with Apex substrate is your assurance of superior mechanical strength and thermal durability.

### THE IQE ADVANTAGE

MIRATECH designs and builds IQE catalyst systems with one objective—minimize the lifetime costs of ownership in a flexible, high-performance, high-value catalyst. IQE is your best choice for cost-efficient catalytic performance.

### THE SMART CHOICE

With the MIRATECH® IQE™ catalyst housing, low cost of ownership starts on Day One—with design and functional specification to first-time permit certainty and easy installation. And that's just for starters.

Ongoing compliance assured, you'll add in big savings from quick, easy and infrequent maintenance, fewer parts to service and inventory, and long-lasting hardworking, no-hassle performance month after month.

The IQE is the low-cost, dollar-wise industrial catalyst system for engines running on natural gas, propane, diesel and dual-fuel requiring Oxidation or Three way catalysts.

### FULL SUPPORT CLOSE TO HOME

Technical services and training provided by MIRATECH, along with field service from authorized MIRATECH representatives, ensures prompt, reliable product support is just a phone call away.

### EMISSIONS & ACOUSTIC SOLUTIONS

For more than 30 years, MIRATECH has been at the forefront in helping industries handle emissions and acoustic standards. Whatever your emissions needs may be, count on MIRATECH for solutions. Just give us a call or visit our website: [miratechcorp.eu](http://miratechcorp.eu)

Sign up at our website for your free subscription to our fact-filled electronic newsletter: [THE EMISSIONS MONITOR](#)